

# DIMM-MX257

---

## Hardware Description

Rev1 / 25.06.2010

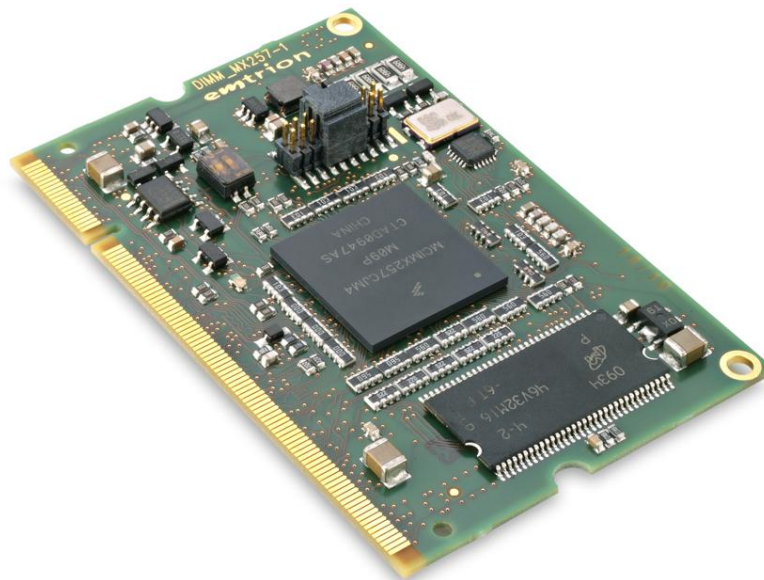

© Copyright 2010 **emtrion GmbH**

All rights reserved. This documentation may not be photocopied or recorded on any electronic media without written approval. The information contained in this documentation is subject to change without prior notice. We assume no liability for erroneous information or its consequences. Trademarks used from other companies refer exclusively to the products of those companies.

Revision: **1 / 25.06.2010**

Rev	Date/Signature	Changes
1	25.06.2010	First revision

## Contents

1	Introduction.....	5
2	Block Diagram.....	6
3	Handling Precautions.....	7
4	Functional Description .....	8
4.1	Processor .....	8
4.1.1	Processor Clocks.....	8
4.2	NAND-Flash.....	9
4.3	RAM.....	9
4.4	Processor Bus.....	9
4.5	Ethernet.....	9
4.6	USB Host.....	10
4.7	USB Device .....	10
4.8	Graphic Display.....	10
4.9	Touch Interface.....	10
4.10	Video Input.....	11
4.11	Audio Interface, SSI port.....	11
4.12	SD-Card Interface.....	11
4.13	Serial Ports.....	11
4.14	I <sup>2</sup> C- Bus.....	12
4.15	SPI Interface .....	12
4.16	CAN .....	12
4.17	Analog Inputs.....	12
4.18	General Purpose I/Os.....	13
4.19	DIP Switches, Status LED .....	13
4.20	Memory Map .....	14
4.21	Interrupts .....	14
4.22	Reset .....	14
4.23	Debugging interface .....	15
4.24	Power Supply .....	15
4.25	DIMM Interface .....	15
5	Pin Assignments.....	16
5.1	J1, SODIMM.....	16
5.2	J2, Debugging Connector.....	19
6	Signal Characteristics .....	20
6.1	J1, SODIMM Connector.....	20
6.2	J2, Debugging Connector.....	23
7	Technical Characteristics .....	24
7.1	Electrical Specifications .....	24
7.2	Environmental Specifications.....	24
7.3	Mechanical Specifications .....	24
7.3.1	Dimensional Drawing.....	25
81.	References.....	26



## 1 Introduction

The DIMM-MX257 processor module is a SODIMM sized CPU board based on the i.MX processor i.MX257 from Freescale.

The processor core runs at 400 MHz and it includes a variety of functions required for multimedia or industry applications. These include LCD controller, camera interface, and sound input/output module.

The module includes a 256 MB NAND-Flash and 64 MB of DDR SDRAM. In addition to the processor internal functions and the memory, a 10/100-Mbps Ethernet PHY is available.

All interfaces are accessible through the 200 pin SODIMM edge connector which complies mechanically with SODIMM memory sockets with 2,5V keying.

The power consumption of the whole board is less than 1,5W.

In the following table the features and interfaces of the DIMM-MX257 processor module are described.

DIMM-MX257
64MB DDR SDRAM
256MB NAND Flash
Processor Bus (16bit data, 24bit addresses, 1CS)
1x 10/100Mbit Ethernet
1x USB Host
1x USB Device
1x LCD Interface 16/18bit max. 800x600 Pixel
1x 4 wire Touch
1x SSI Audio
1x UART RS232
1x SPI
1x I2C
2x CAN
4x ADC
3x IRQ
1x/2x SD Card
1x Video IN 8bit*
2x/3x UART TTL
min. 2/6 GPIO

\*If the Video IN interface is used, the 2<sup>nd</sup> SD Card, the 3<sup>rd</sup> UART TTL and GPIO's can't be used. Please contact emtrion GmbH for further details

The module is available in standard temperature range 0°C to 70°C and in the extended temperature range -40°C to 85°C.

## 2 Block Diagram

The following figure shows the block diagram of the DIMM-MX257.

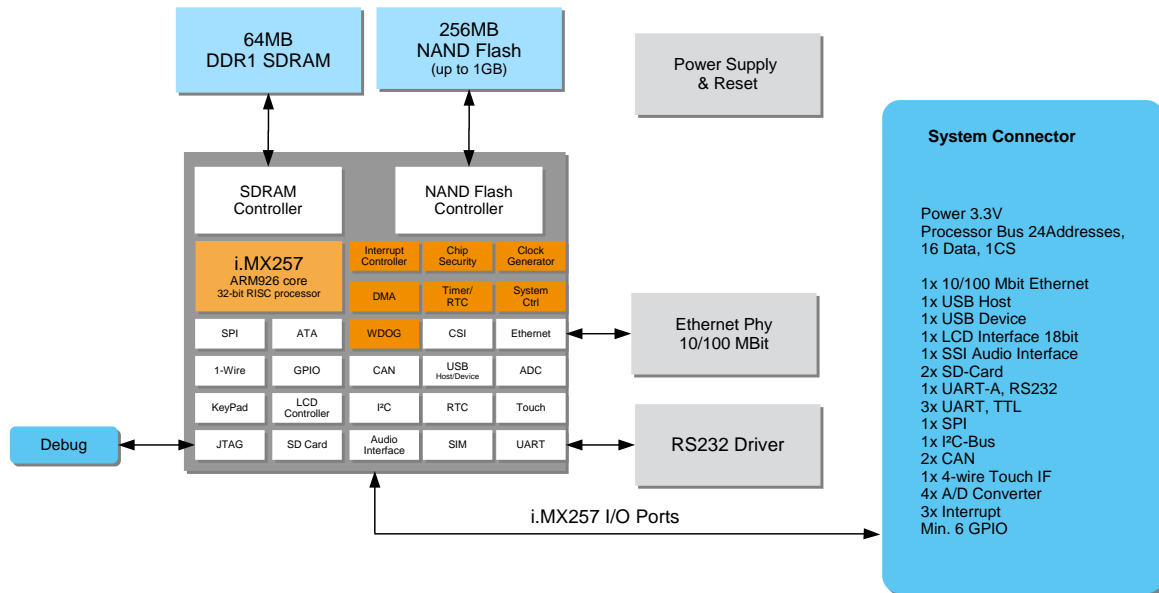

### **3 Handling Precautions**

Please read the following notes prior to installing the DIMM-MX257 processor module. They apply to all ESD (electrostatic discharge) sensitive components:

- The DIMM-MX257 does not need any configurations before installation.
- The module does not provide any on-board ESD protection circuitry – this must be provided by the product it is used in.
- Before installing the module it is recommended that you discharge yourself by touching a grounded object.
- Be sure all tools required for installation are electrostatic discharged as well.
- Before installing (or removing) the module, unplug the power cable from your mains supply.
- Handle the board with care and try to avoid touching its components or tracks.

## 4 Functional Description

### 4.1 Processor

The DIMM-MX257 processor board uses the i.MX processor i.MX257 from Freescale [1], a 32-bit RISC processor which runs at 400MHz.

In addition to the CPU core with MMU, FPU and Caches, this processor provides a lot of features such as:

- Interrupt controller
- Processor Bus Controller with SRAM, PSRAM and NOR Flash interface
- NAND Flash controller
- DDR SDRAM controller
- Four 32-bit timers
- 3/4 UARTs with 2x 32 byte FIFO
- I2C bus interface
- SPI interface
- Video input module with camera capturing module and image processing unit\*
- LCD Controller for TFT displays up to SVGA and 16/18 bpp
- 4 wire Touch controller
- Two CAN controllers
- Ethernet MAC 10/100Mbit
- Sound interface with I2S format
- USB 2.0 Host with high-speed mode
- 1/2 SD Card host controller
- 4-channel A/D converter
- JTAG debug interface

\*If the Video IN interface is used, the 2<sup>nd</sup> SD Card, the 3<sup>rd</sup> UART TTL and GPIO's can't be used. Please contact emtrion GmbH for further details

Further details of the processor can be found in the i.MX257 hardware manual [1].

#### 4.1.1 Processor Clocks

The 24MHz main clock is generated by a quartz crystal. This clock is multiplied by the internal PLL to 400 MHz and then divided by various software configurable dividers.

The following table shows the configured internal clocks:

Clock	Frequency
CPU Clock	400 MHz
Memory Clock	13 MHz
Bus Clock	66,66 MHz
SDRAM Clock	13 MHz
Peripheral Clock	66,66 MHz

The RCLK clock input of the CPU is supplied by a 32,768 kHz clock from the RTC chip and it is used for date and time applications.

## 4.2 NAND-Flash

To store the operating system and application data, 256 MB NAND Flash are provided. A flash memory MT29F2G from Micron is used and connected to the eight bit NAND Flash controller of the processor.

To use the write protect function the WP# Pin of the Flash device is connected to the dedicated WP# pin of the NAND Flash controller of the processor. As default the signal is pulled down and the NAND Flash is protected.

For special applications, the NAND Flash size can be upgraded up to 1GB. (Please contact emtrion GmbH)

## 4.3 RAM

64 MB DDR SDRAM are available as main memory. The memory consists of one 512Mbit DDR SDRAM, type 8M\*16\*4, and is connected to the SDRAM controller. They are clocked at 133 MHz and operated with CAS2.

As RAM device the MT46V32M16P-6 from Micron is used.

The RAM is located in the address range 0x80000000 ... 0x83FFFFFF.

## 4.4 Processor Bus

The processor bus of the i.MX257 with 16bit data and 24bit addresses is routed to the SODIMM connector. The bus clock, the control signals and one chip select signal is also routed to the SODIMM connector. At this processor bus external devices or memory can be connected.

The processor bus signal level is V and the processor bus clock is 66,66MHz.

The address space is in the range 0xA0000000 ... 0xA0FFFFFF.

## 4.5 Ethernet

The Ethernet interface is realized with the processor internal Media Access Controller (MAC) and an external Physical Layer Interface (PHY) LAN8720A from SMSC. The RMII interface is used for communication between the MAC and the PHY.

The Ethernet interface supports the operating modes 100BASE-TX or 10BASE-T, both half- and full duplex. Also HP Auto-MDIX is supported.

The registers of the Ethernet PHY can be configured via the Media Independent Interface (MII).

The Ethernet signal lines as well as two status signals that serve to indicate the link status and the transfer speed are connected to the SODIMM connector. An appropriate 1:1 transformer must be added externally.

#### **4.6 USB Host**

A USB Host interface is used to connect USB devices such as a keyboard, mouse, printer or memory stick.

The USB host interface is realized by the internal host controller of the i.MX257. It complies with the USB specification Rev. 2.0, supporting data transfers at low-speed, full-speed (12MHz) and high-speed (480Mbps).

To switch the bus power the control line USBH\_PEN# is connected to the SODIMM connector. A logical "0" at the processor GPIO1-17 switches the power on, a logical "1" turns the power off. The signal USBH\_OC# reports an overcurrent at the GPIO2-22 ("0" = overcurrent).

The data lines and the two control lines are available at the SODIMM connector. A USB power switch must be added externally. The data lines are internally terminated with 15-K $\Omega$  pulldown resistors.

#### **4.7 USB Device**

The USB device port allows the transmission of data to an external host, e.g. between a host PC and Windows CE via Active Sync.

The interface is realized by the internal device controller of the i.MX257. The interface is USB 2.0 compliant, supporting data transfers at low-speed, full-speed (12MHz) and high-speed (480Mbps).

The data lines and the control line VBUS are available at the SODIMM connector. External 15-K $\Omega$  pulldown resistors are not required.

#### **4.8 Graphic Display**

The LCD controller of the i.MX257 can drive TFT displays with resolutions up to SVGA at 16/18bpp. The pixel clock for the display data is generated by an internal 64-bit pattern. Thus all timings can individually be adapted by software to the connected display.

All data and control lines are available at the SODIMM connector.

#### **4.9 Touch Interface**

A 4-wire touch interface is implemented via the processor internal touch controller. The pen interrupt is supported by that controller.

The touch interface signals are available at the SODIMM connector.

If the touch interface is not used, these signals can be used as general purpose ADC input signals.

The touch interface can also be used as a 5-wire interface. In this case the analog input ANA\_IN4 can be used as the wiper signal. Please contact emtrion GmbH for further details about this option.

#### 4.10 Video Input

The i.MX257 has a video input unit (CSI) which can be used with different video sources, such as video codec or CMOS camera modules.

The interface at the DIMM-MX257 is realised with an 8-bit data-bus available at the SODIMM connector and supports various input formats.

To switch between two video sources the signal VIO\_SRC (GPIO3-17) is available. To reset the video codec on the base board the signal VIO\_RST (GPIO2-21) can be used. Both signals are connected to the SODIMM connector

**Attention:**

If this interface is used, the 2<sup>nd</sup> SD Card, UART\_D and GPIO\_A to GPIO\_D can't be used. Please contact emtrion GmbH for further details about this option.

#### 4.11 Audio Interface, SSI port

The i.MX257 processor has an integrated Audio module that can be used to send and receive audio data from external audio codecs.

The interface is connected to SODIMM connector, which allows the selection of an external audio codec. The processor can work in the SSI slave mode.

#### 4.12 SD-Card Interface

The i.MX257 includes two SD Card interfaces to drive memory- or I/O cards. The signals are routed with all necessary pull up resistors to the SODIMM connector.

**Attention:**

The 2<sup>nd</sup> SD Card is only available if the Video IN interface is not used. Please contact emtrion GmbH for further details about this option.

#### 4.13 Serial Ports

The DIMM-MX257 has up to four serial ports, depended on the module option. All serial ports are integrated in the processor i.MX257.

An overview of the UART interfaces is shown as follows:

i.MX257 interface	SODIMM name	handshake signals
UART1	UART_A	RTS, CTS
UART3	UART_B	-

UART5*	UART_D	-
UART2	UART_E	-

\*UART5 is only available if the Video IN interface is not used. Please contact emtrion GmbH for further details about this option.

UART\_A has been implemented as a RS232 port. The signal lines of UART\_B, UART\_D and UART\_E have LVTTTL level and will need to be configured by external drivers.

RS232 adaptors that can be plugged to a pin header are available from emtrion GmbH.

#### 4.14 I<sup>2</sup>C- Bus

The i.MX257 provides an I<sup>2</sup>C bus interface with transmission speeds up to 400 kb/s. The interface operates as a master.

One device is connected to the bus on DIMM-MX257:

Slave	Device	Chip Address
Real Time Clock	DS1337U+	0x68

The bus connects to the SODIMM connector. The SCL and SDA lines are pulled up with 2,2kΩ resistors to 3,3V.

#### 4.15 SPI Interface

The SPI interface of the i.MX257 processor is connected to the SODIMM connector. The four signals SPI\_SCK, SPI\_CS#, SPI\_MOSI and SPI\_MISO are routed to the SODIMM connector.

#### 4.16 CAN

The i.MX257 includes two CAN controllers. The TX and RX signals are routed with all necessary pull up resistors to the SODIMM connector. For each CAN interface a CAN transceiver must be realized on the base board.

The signal level is 3,3V.

#### 4.17 Analog Inputs

The i.MX257 contains a four channel A/D converter with a resolution of 12 bit. The maximum conversion time per channel is 8μs (125kHz).

The analog inputs have a permissible input voltage range of 0V ... 3,3V and connected directly to the SODIMM connector.

The analog inputs ANA\_IN1, ANA\_IN2 and ANA\_IN3 can be used in different ways.

1. Normal analog inputs
2. Monitoring the onboard generated voltages 2,5V, 1,5V and 1,45V, via the on chip ADC.\*

- Monitoring the onboard generated voltages 2,5V, 1,5V and 1,45V, via an external ADC off board.\*

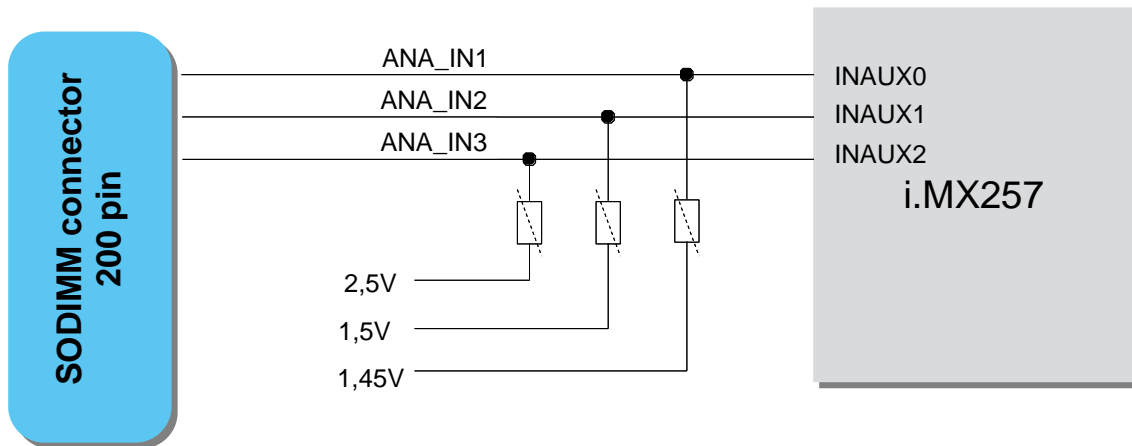

\*Please contact emtrion GmbH for that option.

#### 4.18 General Purpose I/Os

Four port pins of the processor which can be used as GPIOs are routed to the SODIMM connector.

SIGNAL	i.MX257 Port	Direction
GPIO_A*	GPIO1-30	In/Out
GPIO_B*	GPIO1-30	In/Out
GPIO_C*	GPIO1-7	In/Out
GPIO_D*	GPIO4-21	In/Out
GPIO_E	GPIO1-26	In/Out
GPIO_F	GPIO4-28	In/Out

\*This GPIO is only available if the Video IN interface is not used. Please contact emtrion GmbH for further details about this option.

The port pin GPIO\_E can be used as PWM output.

The signal level of each GPIO pin is 3,3V.

#### 4.19 DIP Switches, Status LED

Two DIP switches are on the DIMM-MX257. Via that DIP switches the boot mode of the DIMM-MX257 module can be configured. If a switch is ON the corresponding bit is read as 1. If it is OFF the bit is read as 0. The following table describes the boot mode options.

SW1	SW2	Boot Mode
OFF	OFF	Internal Boot
OFF	ON	Reserved
ON	OFF	External (Direct) Boot
ON	ON	USB/UART Serial Boot

Further details of the boot mode options can be found in the i.MX257 hardware manual [1].

A bicolour LED is connected to the port pins GPIO2-21 and GPIO3-19 of the i.MX257. If GPIO3-19 is high a green LED is lighting, if GPIO2-21 is high a red LED is lighting. If both ports are high both LEDs are on, which results in a yellow light.

## 4.20 Memory Map

In the following table the memory spaces of the external memory or devices is shown.

Function	Bus Width	Address Region
64 MB DDR SDRAM	16-bit	80000000 – 83FFFFFF
SODIMM	8/16-bit	A0000000 – A0FFFFFF

The timing characteristics of DDR SDRAM area is programmed according to the requirements of the DIMM-MX257 processor board.

The SODIMM area is reserved for external extensions and therefore configured with the slowest timing.

## 4.21 Interrupts

The processor i.MX257 has an integrated interrupt controller that analyzes all interrupt sources, prioritizes them and outputs the interrupt with the highest priority to the processor.

Each GPIO Input can be configured as an interrupt input. Eight dedicated interrupt input pins are available for external devices.

The use of the interrupt inputs is shown in the following table:

GPIO Port	Source
GPIO3-15	SODIMM (IRQ1)
GPIO2-31	SODIMM (IRQ2)
GPIO3-0	SODIMM (IRQ3)
GPIO4-3	DS1337

The signal level of each interrupt is 3,3V.

## 4.22 Reset

There are several ways for issuing a reset signal:

- A voltage monitor checks the 3,3V supply voltage of the board, the 1,45V Core voltage of the processor and the 2,5V DDR SDRAM voltage.
- Via the active low signal RESI# at the SODIMM connector
- Via the active low signal JTAG\_RESI# at the Debug connector
- Via software by setting port pin HRESET\_B (GPIO3-18) to 0 (only peripheral reset)

All resets are hardware resets of the whole board and issue a cold reset of the processor.

The duration of the reset signal is min. 140ms. For resetting external devices the reset signal is available as an output at the SODIMM connector.

#### 4.23 Debugging interface

At the 20 pole header J2 all signals of the ARM9 debug interface and the Boot Mode signals are available.

Please contact emtrion GmbH for further details how to connect an emulator to J2.

#### 4.24 Power Supply

A voltage of +3,3V, +/- 5%, @ max. 0.4 A must be supplied via the SODIMM connector. Further voltages for the processor and the other parts are generated on board.

#### 4.25 DIMM Interface

All interface signals of the board and an SRAM like bus interface for external peripheral additions are available at the SODIMM connector which is named DIMM interface.

The DIMM interface is a 200 pos SODIMM connector that fits mechanically into a regular DDR1 SODIMM memory socket with 2,5V keying. These sockets are available from various manufacturers.

Usage details of the connector and its electrical and mechanical characteristics can be found later in this document.

##### Notes:

The pin out of the SODIMM connector is NOT compatible with memory sockets. Insertion into a socket with wrong pin out may damage the DIMM-MX257 and the carrier board.

Most of the pins are directly connected with the processor i.MX257n. For detailed electrical specification please refer to Section 3, Electrical Characteristics, in the i.MX257 datasheet [2]

## 5 Pin Assignments

### 5.1 J1, SODIMM

Type SODIMM, 200 pos, 2,5V keying

Pin	Signal	Interface		Signal	Pin
1	SPEED_LED#	Ethernet	USB Host	USBH_PEN#	2
3	ETH_TDP			USBH_OC#	4
5	ETH_TDM			USBH_DM	6
7	GND			USBH_DP	8
9	ETH_RDP		USB Device	USBF_VBUS	10
11	ETH_RDM			USBF_DM	12
13	LINK_LED#			USBF_DP	14
15	+3V3		Power		GND
17	CAN1_TX	CAN	UART	UART1_TXD#	18
19	CAN1_RX			UART1_RXD#	20
21	UART2_TXD	UART		UART1_RTS#	22
23	UART2_RXD			UART1_CTS#	24
25	UART5_TXD	UART	Touch	Touch_XP	26
27	UART5_RXD			Touch_XM	28
29	n/c			Touch_YP	30
31	n/c			Touch_YM	32
33	UART3_TXD	UART	A/D	ANA_IN 1	34
35	UART3_RXD			ANA_IN 2	36
37	ANA_IN4	A/D		ANA_IN 3	38
39	+3V3	Power		GND	40
41	n/c	LCD		n/c	42
43	n/c		n/c	44	
45	n/c		n/c	46	
47	LCD_D16		LCD_D17	48	
49	LCD_D14		LCD_D15	50	
51	LCD_D12		LCD_D13	52	
53	LCD_D10		LCD_D11	54	
55	LCD_D8		LCD_D9	56	
57	LCD_D6		LCD_D7	58	
59	LCD_D4		LCD_D5	60	

61	LCD_D2			LCD_D3	62		
63	LCD_D0			LCD_D1	64		
65	+3V3			GND	66		
67	n/c			n/c	68		
69	LCD_DISP			LCD_DCK	70		
71	LCD_HSYN			LCD_DON	72		
73	LCD_VSYN			n/c	74		
75	VOU_DEST			n/c	76		
77	VOU_RST#	<b>VIO</b>		VIO_D7	78		
79	n/c			VIO_D6	80		
81	VIO_CKO			VIO_D5	82		
83	VIO_CLK			VIO_D4	84		
85	VIO_HD			VIO_D3	86		
87	VIO_VD			VIO_D2	88		
89	VIO_SRC			VIO_D1	90		
91	VIO_RST#			VIO_D0	92		
93	+3V3			<b>Power</b>		GND	94
95	SDC2_D0			<b>SDC2</b>	<b>SDC1</b>	SDC1_D0	96
97	SDC2_D1	SDC1_D1	98				
99	SDC2_D2	SDC1_D2	100				
101	SDC2_D3	SDC1_D3	102				
103	SDC2_CMD	SDC1_CMD	104				
105	SDC2_CLK	SDC1_CLK	106				
107	SDC2_CD#	SDC1_CD#	108				
109	SDC2_WP	SDC1_WP	110				
111	SPI_SS#	<b>SPI</b>		SPI_MISO	112		
113	SPI_SCK			SPI_MOSI	114		
115	SCL	<b>I2C</b>	<b>Audio</b>	AUDIO_BCK	116		
117	SDA			AUDIO_LRC	118		
119	n/c			AUDIO_DATI	120		
121	n/c			AUDIO_DATO	122		
123	GND	<b>Power</b>			n/c	124	
125	CAN2_RX	<b>CAN</b>		CAN1_TX	126		

127	n/c	<b>GPIO</b>	GPIO_D	128
129	n/c		GPIO_C	130
131	GPIO_F		GPIO_B	132
133	GPIO_E		GPIO_A	134
135	+3V3	<b>Power</b>	GND	136
137	A22	<b>Address A[23:0]</b>	A23	138
139	A20		A21	140
141	A18		A19	142
143	A16		A17	144
145	A14		A15	146
147	A12		A13	148
149	A10		A11	150
151	A8		A9	152
153	A6		A7	154
155	A4		A5	156
157	A2		A3	158
159	A0		A1	160
161	+3V3	<b>Power</b>	GND	162
163	D14	<b>Data D[15:0]</b>	D15	164
165	D12		D13	166
167	D10		D11	168
169	D8		D9	170
171	D6		D7	172
173	D4		D5	174
175	D2		D3	176
177	D0		D1	178
179	CKIO	<b>Bus Control</b>	n/c	180
181	n/c		n/c	182
183	RD#		IRQ1	184
185	RD/WR#		IRQ2	186
187	WE0#		IRQ3	188
189	WE1#		RESO#	190
191	n/c		RESI#	192
193	n/c		n/c	194
195	WAIT#		n/c	196

<b>197</b>	CS#		n/c	<b>198</b>
<b>199</b>	BAT	<b>Power</b>	GND	<b>200</b>

## 5.2 J2, Debugging Connector

Type 20-pin connector, Samtec FTSH-110-01-FM-DV-K-P

Pin	Signal	Pin	Signal
1	RTCK	2	TCK
3	GND	4	GND
5	+3V3	6	TRST#
7	+3V3	8	+3V3
9	n/c	10	TDO
11	BOOT_MODE1	10	JTAG_DE#
13	BOOT_MODE0	10	TMS
15	JTAG_MODE	10	TDI
17	GND	18	DBG_ACK
19	JTAG_RESI#	20	JTAG_RESET#

## 6 Signal Characteristics

Abbreviations:

AI analogue input  
 AO analogue output  
 A I/O analogue bidirectional  
 I digital input  
 O digital output  
 I/O digital bidirectional

PU xK x K $\Omega$  pullup resistor  
 PD xK x K $\Omega$  pulldown resistor  
 SR xR x  $\Omega$  series resistor  
 IPU xK processor internal x K $\Omega$  pullup resistor  
 IPD xK transistor internal x K $\Omega$  pulldown resistor

### 6.1 J1, SODIMM Connector

Name	Direction	Add. Wiring	Volt [V]	Description
<b>Ethernet</b>				
SPEED_LED#	O	-	3,3	100 Mbit indicator
SPEED_LED#	O	-	3,3	100 Mbit indicator
ETH_TDP	AO	-	-	TX diff. output pos.
ETH_TDM	AO	-	-	TX diff. output neg.
ETH_RDP	AI	-	-	RX diff. input pos.
ETH_RDN	AI	-	-	RX diff. input neg.
LINK_LED#	O	-	3,3	traffic indicator
<b>USB Host #</b>				
USBH_PEN#	O	PU 100K IPU 100K	3,3	Power enable for switch
USBH_OC#	I	PU 100K IPU 100K	3,3	Overcurrent from switch
USBH_DP	I/O	SR 33	3,3	Diff. data positive
USBH_DM	I/O	SR 33	3,3	Diff. data negative
USB Device				
USBF_VBUS	I	-	5	VBUS detection
USBF_DP	I/O	-	3,3	Diff. data positive
USBF_DM	I/O	-	3,3	Diff. data negative
<b>UART</b>				
UART1_TXD#	O	IPU 100K	RS232	RS232 transmit data
UART1_RXD#	I	IPU 100K	RS232	RS232 receive data
UART1_RTS#	O	IPU 100K	RS232	RS232 modem control
UART1_CTS#	I	IPU 100K	RS232	RS232 modem control
UART2_TXD#	O	IPU 100K	3,3	transmit data
UART2_RXD#	I	IPU 100K	3,3	receive data
UART3_TXD#	O	IPU 100K	3,3	transmit data
UART3_RXD#	I	IPU 100K	3,3	receive data

UART5_TXD#	O	IPU 100K	3,3	transmit data
UART5_RXD#	I	IPU 100K	3,3	receive data
<b>CAN</b>				
CAN1_TX	O	PU 10K IPU 100K	3,3	transmit data
CAN1_RX	I	PU 10K IPU 100K	3,3	receive data
CAN2_TX	O	PU 10K IPU 100K	3,3	transmit data
CAN2_RX	I	PU 10K IPU 100K	3,3	receive data
<b>4-Wire Resistive Touch Interface</b>				
TOUCH_XP	A I/O	-	3,3	X plus terminal
TOUCH_XM	A I/O	-	3,3	X minus terminal
TOUCH_YP	A I/O	-	3,3	Y plus terminal
TOUCH_YM	A I/O	-	3,3	Y minus terminal
<b>Analog Input</b>				
ANA_IN1	A I/O	-	3,3	12 bit analog input
ANA_IN2	A I/O	-	3,3	12 bit analog input
ANA_IN3	A I/O	-	3,3	12 bit analog input
ANA_IN4	A I/O	-	3,3	12 bit analog input
<b>LCD (Graphic Display)</b>				
LCD_DON	O	-	3,3	LCD display enable signal
LCD_DISP	O	PD 10K	3,3	LCD data enable signal
LCD_VSYNC	O	PD 10K	3,3	LCD frame sync output
LCD_HSYNC	O	PD 10K	3,3	LCD line sync output
LCD_D[17:16]	O	IPU 100K	3,3	LCD colour data
LCD_D[15, 13, 12, 10: 5, 2, 1]	O	PD 10K	3,3	LCD colour data
LCD_D[14, 11, 4, 3, 0]	O	PU 10K	3,3	LCD colour data
LCD_DCK	O	PD 10K	3,3	LCD data clock
<b>VIO (Video Input Unit)*</b>				
VIO_D[7:0]	I	IPU 100K	3,3	Video image input data
VIO_CLK	I	IPU 47K	3,3	Video clock input
VIO_HD	I	IPU 47K	3,3	Video hsync input
VIO_VD	I	IPU 47K	3,3	Video vsync input
VIO_CKO	O	IPU 47K	3,3	Clock output
VIO_SRC	O	IPU 100K	3,3	Selection of either camera or video codec input
VIO_RST#	O	IPU 100K	3,3	Reset signal for video device
<b>SPI</b>				
SPI_CS#	O	IPU 100K	3,3	Chip select output
SPI_SCK	O	IPU 100K	3,3	Clock output
SPI_MISO	I	IPU 100K	3,3	Input data from slave
SPI_MOSI	O	IPU 100K	3,3	Output data to slave
<b>SD Card Interface</b>				
SDC1_D[3:0]	I/O	IPU 47K	3,3	SDC data
SDC1_CMD	I/O	IPU 47K	3,3	CMD signal
SDC1_CLK	O	IPU 47K	3,3	SDC Clock output

SDC1_CD#	I	PU 100K	2,5	Card detect input
SDC1_WP	I	PU 100K	2,5	Write protect input
SDC2_D[3:0]	I/O	IPU 47K	3,3	SDC data
SDC2_CMD	I/O	IPU 47K	3,3	CMD signal
SDC2_CLK	O	IPU 47K	3,3	SDC Clock output
SDC2_CD#	I	PU 100K	2,5	Card detect input
		IPU 100K		
SDC2_WP	I	PU 100K	2,5	Write protect input
		IPU 100K		
<b>I2C</b>				
SCL	I/O	PU 2K2	3,3	I <sup>2</sup> C clock signal
		IPU 100K		
SDA	I/O	PU 2K2	3,3	I <sup>2</sup> C data signal
		IPU 100K		
<b>Audio</b>				
AUDIO_BCK	I/O	IPU 100K	3,3	Sound bit clock
AUDIO_LRC	I	IPU 100K	3,3	Sound L/R signal
AUDIO_DATI	I	IPU 100K	3,3	Sound serial input data
AUDIO_DATO	O	IPU 100K	3,3	Sound serial output data
General Purpose I/O				
GPIO[A:D, F]	I/O	IPU 100K	3,3	digital input / output
GPIO_E	I/O	PD 10K	3,3	digital input / output
<b>Bus Interface</b>				
A[23:0]	O	SR 56R	2,5	Processor address bus
D[15:0]	I/O	SR 39R	3,3	Processor data bus
		IPU 100K		
CKIO	O	SR 47R	2,5	66 MHz bus clock
WAIT#	I	PU 10K	3,3	Wait Input
		IPU 100K		
CS#	O	PU 10k	2,5	Chip select output
		SR 56R		
RD#	O	SR 56R	2,5	Read signal
WE0#	O	SR 56R	2,5	Write access on even address
WE1#	O	SR 56R	2,5	Write access on odd address
RD/WR#	O	SR 56R	2,5	Data direction signal
IRQ1	I	PU 10K	3,3	Interrupt input
		IPU 100K		
IRQ2	I	PU 10K	3,3	Interrupt input
		IPU 100K		
IRQ3	I	PU 10K	3,3	Interrupt input
		IPU 100K		
RESI#	I	PU 10K	3,3	Reset input from carrier board
RESO#	O	-	3,3	Reset output to carrier board
BAT	-	-	1,8 – 3,0	Battery backup input for RTC
+3V3	-	-	-	+ 3,3V supply
GND	-	-	-	Ground

\*If the Video IN interface is used, the 2<sup>nd</sup> SD Card, the 3<sup>rd</sup> UART TTL and GPIO's can't be used. Please contact emtrion GmbH for further details

## 6.2 J2, Debugging Connector

Name	Direction	Add. Wiring	Volt [V]	Description
<b>Debug Interface</b>				
TCK	I	PD 10K IPD 100K	3,3	JTAG clock input
TMS	I	PU 10K	3,3	JTAG mode select input
TRST#	I	PD 10K IPU 47K	3,3	H-UDI reset input
TDI	I	PU 10K IPU 47K	3,3	Data input
TDO	O	SR 33 PU 10K IPU 47K	3,3	Data output
RTCK	O	PD 10K	3,3	return TCK
JTAG_MODE	I	PD 10K IPU 100K	3,3	
JTAG_DE#	I	PU 10K IPU 47K	3,3	
DBG_ACK	O	PD 10K	3,3	
<b>Miscellaneous</b>				
JTAG_RESET#	I	PU 100K	3,3	Debugger Reset input
JTAG_RESI#	I	PU 10K	3,3	Manual Reset input
BOOT_MODE0	I	PD 10K IPD 100K	3,3	Boot mode selection
BOOT_MODE1	I	PD 10K IPD 100K	3,3	Boot mode selection
+3V3	-	-	-	+ 3,3V supply
GND	-	-	-	Ground

## 7 Technical Characteristics

### 7.1 Electrical Specifications

<b>Supply voltage</b>	3,3 V, +/-5%
<b>Current consumption</b>	0.4 A max.

### 7.2 Environmental Specifications

<b>Operating temperature</b>	
Standard:	0 ... +70°C
Extended:	-40 ... +85°C
<b>Storage temperature</b>	-40 ... +125°C
<b>Relative humidity</b>	0 ... 95 %, non-condensing

### 7.3 Mechanical Specifications

<b>Weight</b>	approx. 16 g
<b>Board</b>	Glasepoxi FR-4, UL-listed, 8 layers
<b>Dimensions</b>	67.6 mm x 45.0 mm x 10.0 mm

### 7.3.1 Dimensional Drawing

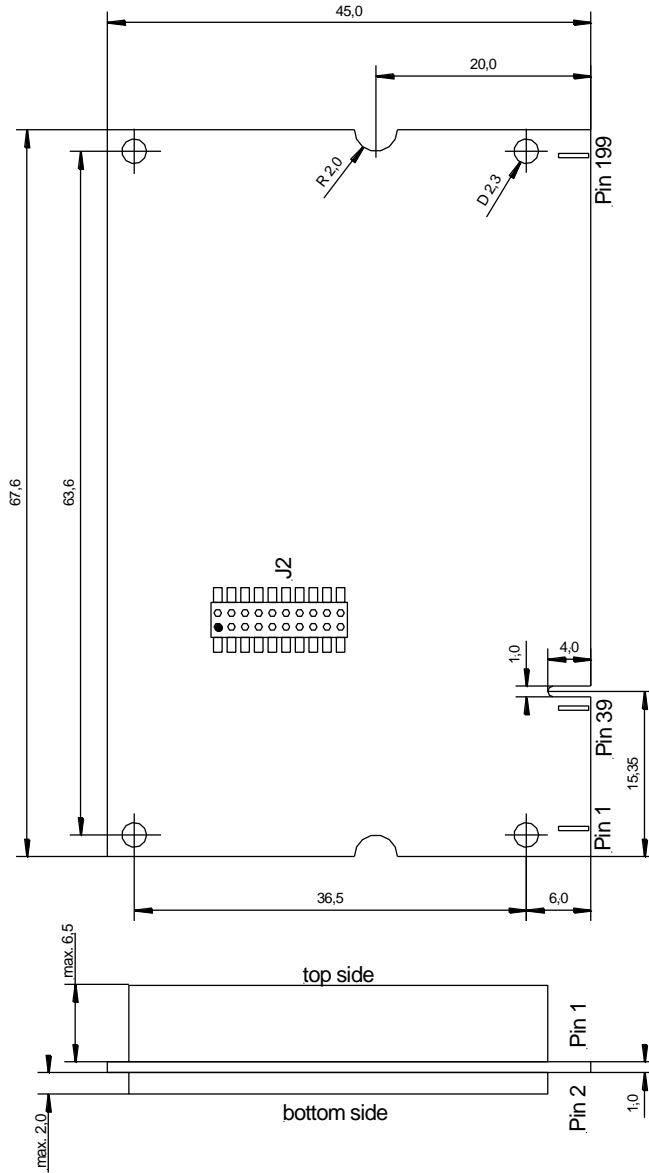

## **8 1. References**

- [1] i.MX257  
Hardware Manual  
i.MX25 Multimedia Applications Processor Reference Manual  
Rev. 1, 06/2009  
Freescale semiconductor
  
- [2] i.MX257  
Datasheet  
i.MX25 Applications Processor for Consumer and Industrial Products  
Rev. 4, 06/2010  
Freescale semiconductor