

emSTAMP-Neon-CMx

Hardware Manual

Rev4 / 17.02.2020

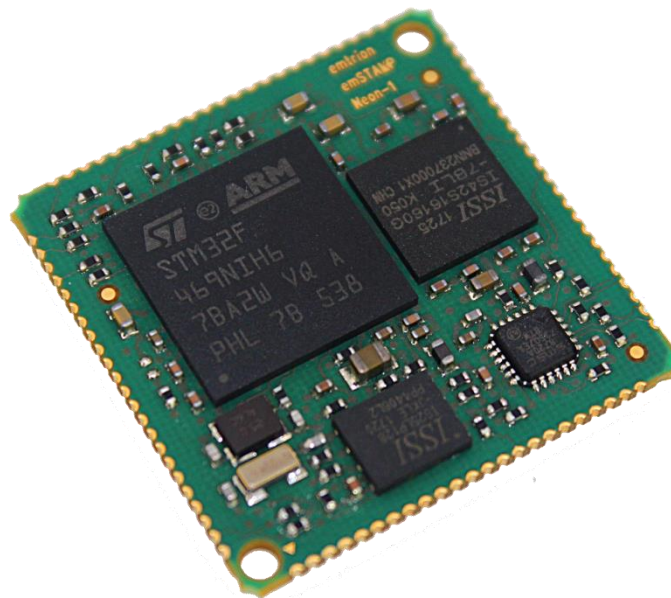

© Copyright 2020 **emtrion GmbH**

All rights reserved. This documentation may not be photocopied or recorded on any electronic media without written approval. The information contained in this documentation is subject to change without prior notice. We assume no liability for erroneous information or its consequences. Trademarks used from other companies refer exclusively to the products of those companies.

Revision: **4 / 17.02.2020**

Rev	Date/Signature	Changes
1	17.07.2018/We	First revision
2	19.09.2019/We	Added new variant emSTAMP-Neon-CM7 with STM32F769 CPU
3	27.09.2019/We	Chapter for USB 2.0 Device added. Chapter for USB 2.0 Host updated. USB-Pins in chapter "castellation connector" updated.
4	17.02.2020/We	Added new variant emSTAMP-Neon-CM479 with STM32F479 CPU. Chapter of recommended footprint updated.

Table of Content

1	Introduction.....	4
2	Handling precautions.....	5
3	Block Diagrams.....	6
3.1	Block Diagram emSTAMP-Neon-CM479.....	6
3.2	Block Diagram emSTAMP-Neon-CM7.....	6
4	Functional Description.....	7
4.1	Module Variants.....	7
4.1.1	Variant emSTAMP-Neon-CM4.....	7
4.1.2	Variant emSTAMP-Neon-CM479.....	7
4.1.3	Variant emSTAMP-Neon-CM7.....	7
4.1.4	Processor Clocks.....	7
4.1.5	Processor features.....	8
4.1.6	Boot Configuration.....	9
4.2	SDRAM.....	9
4.3	Serial NOR-Flash.....	9
4.4	Graphic Output.....	10
4.4.1	Color mapping in 16/18bit mode.....	10
4.5	Ethernet.....	11
4.6	USB 2.0 Host.....	11
4.7	USB 2.0 Device.....	12
4.8	CAN Interface.....	12
4.9	SDIO Interface.....	12
4.10	Serial Ports.....	13
4.11	I ² C Interface.....	13
4.12	SPI Interfaces.....	13
4.13	Audio Interface.....	14
4.14	GPIOs / PWM.....	14
4.15	Analog to Digital Converter (ADC).....	14
4.16	Digital to Analog Converter (DAC).....	15
4.17	WKUP Signal.....	15
4.18	Reset.....	15
4.19	JTAG Debug.....	15
4.20	Power Supply.....	16
4.20.1	+3V3 Supply.....	16
4.20.2	Battery backup voltage V _{BAT}	16
5	Castellation Connector.....	17
6	Technical Characteristics.....	19
6.1	Electrical Specifications.....	19
6.2	Environmental Specifications.....	19
6.3	Mechanical Specifications.....	19
7	Dimensional Drawing.....	20
8	Recommended patterns for soldering.....	20

9 References..... 21

1 Introduction

This document is written for the three available emSTAMP-Neon variants with different CPU types:

- **emSTAMP-Neon-CM4** with Cortex-**M4** STM32F469NIH6 CPU
- **emSTAMP-Neon-CM7** with Cortex-**M7** STM32F769NIH6 CPU
- **emSTAMP-Neon-CM479** with Cortex-**M4** STM32F479NIH6 CPU

For this document the following name convention will be used. The names **emSTAMP-Neon-CMx** and **STM32-Fxx9NIH6** will be used for both variants.

The emSTAMP-Neon-CMx modules are CPU board of emtrions emSTAMP-family, based on the STM32Fxx9NIH6 microcontroller from STMicroelectronics. The microcontrollers may be clocked up to 180MHz (emSTAMP-Neon-CM4 and -CM479) and 216MHz (emSTAMP-Neon-CM7). They include a variety of functions required for IOT or industrial applications.

The CPU boards are designed as a compact module with castellated mounting holes that can be soldered directly on a baseboard.

The development board emSBC-Neon-CMx with an already equipped emSTAMP-Neon-CMx module is also available at emtrion. The development board provides power supply and access to all of the emSTAMP-Neon-CMx interfaces. It is targeted to quickly start into the product development.

This manual documents the function and available interfaces of the emSTAMP-Neon-CMx processor module.

2 Handling precautions

Please read the following notes prior to installing the processor module. They apply to all ESD (electrostatic discharge) sensitive components:

- The module does not need any configurations before installing
- The CPU module does not provide any on-board ESD protection circuitry – this must be provided by the product it is used in.
- Before installing the module it is recommended that you discharge yourself by touching a grounded object.
- Be sure all tools required for installation are electrostatic discharged as well.
- Before installing (or removing) the module, unplug the power cable from your mains supply.
- Handle the board with care and try to avoid touching its components or tracks.

3 Block Diagrams

3.1 Block Diagram emSTAMP-Neon-CM479

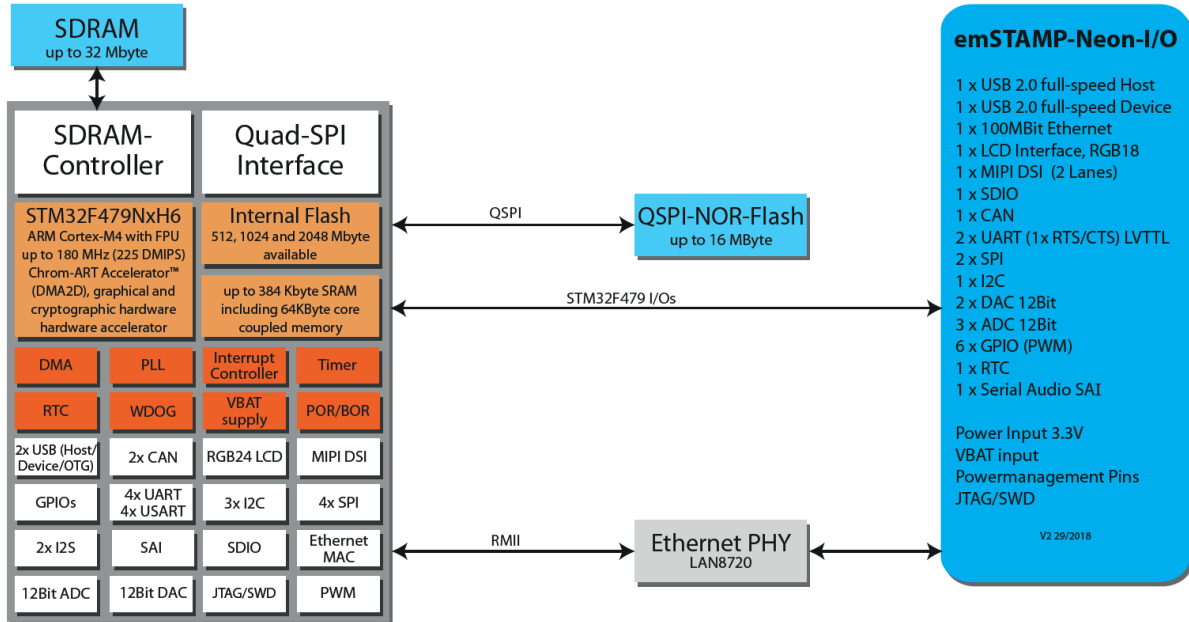

Block Diagram with the available Interfaces of the emSTAMP-Neon-CM479

3.2 Block Diagram emSTAMP-Neon-CM7

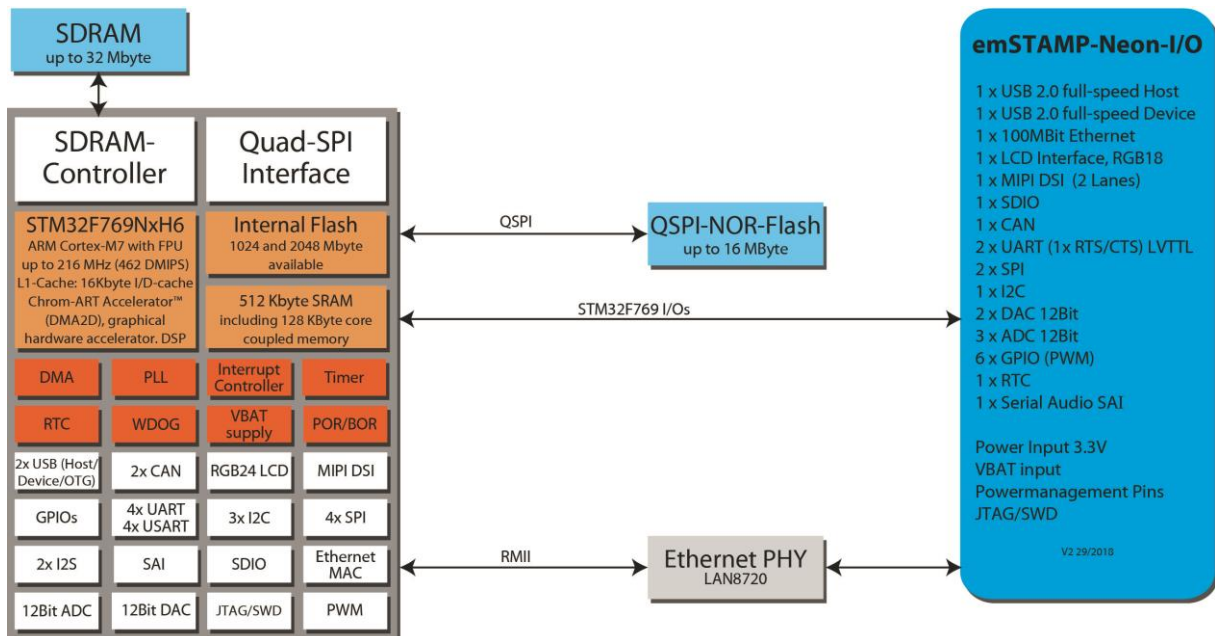

Block Diagram with the available Interfaces of the emSTAMP-Neon-CM7

4 Functional Description

4.1 Module Variants

4.1.1 Variant emSTAMP-Neon-CM4

The emSTAMP-Neon-CM4 processor module uses the STM32F469NIH6 from STMicroelectronics [2] which includes an ARM Cortex-M4 with FPU and runs up to 180 MHz clock frequency.

4.1.2 Variant emSTAMP-Neon-CM479

The emSTAMP-Neon-CM4 processor module uses the STM32F479NIH6 from STMicroelectronics [6] which includes an ARM Cortex-M4 with FPU and runs up to 180 MHz clock frequency.

This CPU has a cryptographic processor and provides hardware acceleration for

- AES 128, 192, 256
- DES and Triple DES,
- HASH (MD5, SHA-1, SHA-224, SHA-256) and HMAC

4.1.3 Variant emSTAMP-Neon-CM7

The emSTAMP-Neon-CM7 processor module uses the STM32F769NIH6 from STMicroelectronics [4] which includes an ARM Cortex-M7 with double precision FPU (64 bit) and runs up to 216 MHz clock frequency. The most important changes of the STM32F768NIH6 are listed below:

- L1-cache: 16 KByte I/D cache
- 216 MHz maximum clock frequency
- 462 DMIPS @ 216 MHz
- 512 KByte internal SRAM
- JPEG codec in hardware
- Double precision FPU (64 bit)

4.1.4 Processor Clocks

The processor is clocked by the HSE oscillator, which is connected to a 25 MHz crystal. Several internal dividers and PLLs multiply the 25 MHz clock input to the internally needed clocks. The SysClock is set to its maximum speed of 180MHz (emSTAMP-Neon-CM4/CM479) and 216MHz (emSTAMP-Neon-CM7).

The 25MHz clock signal is used as clock input for the Ethernet-Phy equipped on the emSTAMP-Neon-CMx module. The 25MHz clock is provided at the Microcontroller Clock Output pin (MCO1) of the processor.

A 32.768 KHz crystal is connected to the Low Speed External oscillator (LSE) of the processor. Its main application is to generate the clock for the RTC of the processor.

More information about the clock system is described in the chapter "Reset and Clock Control (RCC)" of the Reference manuals of STMicroelectronics [1] and [3].

4.1.5 Processor features

In addition to the CPU core, the processors provide a lot of functionality. The following features are provided by the emSTAMP-Neon-CMx modules:

- SDRAM controller
- QSPI-interface for serial-NOR-Flash
- Ethernet 10/100Mbit
- 1x USB 2.0 host in full-speed mode
- 1x USB 2.0 device in full-speed mode
- 1x JTAG debug interface
- 1x LCD controller with 18-bit RGB interface for TFT displays up to 1024x768 (XGA)
- 1x CAN controller
- 1x SDIO controller
- 1x Sound Interface with I²S format
- 2x UART interface (1x with RTS/CTS)
- 2x SPI interface
- 1x I2C Interface
- 3x ADCs with 12-bit resolution
- 2x DAC with 12-bit resolution
- 6x GPIOs with PWM-functionality
- Real time clock
- System reset and wake-up control

4.1.6 Boot Configuration

The STM32Fxx9 offers three boot modes which are selected by the two CPU pins BOOT[1:0]. The different boot modes are shown in the table below:

BOOT1	BOOT0	Boot mode
0	0	Booting from flash memory
0	1	Factory programmed Bootloader is executed
1	0	Booting from flash memory
1	1	Booting from SRAM

On the emSTAMP-Neon-CMx module the two boot configuration pins BOOT[1:0] are both connected to a 1k pull-down resistor. By this the default boot mode of the CPU is booting from flash memory. To be able to change the boot mode of the CPU, the pins BOOT[1:0] are connected to the castellated mounting holes of the module.

Signal	Module pin	CPU pin
BOOT_0	14	BOOT0
BOOT_1	15	PB2_BOOT1

4.2 SDRAM

The emSTAMP-Neon-CMx CPU module provides 32MByte SDRAM as main memory. The RAM is connected via a 16bit wide data bus und may be clocked up to 90MHz. This memory can be used as framebuffer by the LCD controller of the CPU.

Please contact emtrion GmbH, if you require a smaller RAM size.

4.3 Serial NOR-Flash

A serial NOR-Flash with QSPI-Interface and a memory size of 16MByte is integrated on the CPU module. The memory is connected to Bank1 of the QUADSPI interface.

Please contact emtrion GmbH, if you require a smaller flash size.

Signal	Module pin	CPU pin
QUADSPI_BK1_IO0	-	PF8
QUADSPI_BK1_IO1	-	PD12
QUADSPI_BK1_IO2	-	PF7
QUADSPI_BK1_IO3	-	PF6
QUADSPI_BK1_NCS	-	PB6
QUADSPI_CLK	-	PF10

4.4 Graphic Output

On the emSTAMP-Neon-CMx module the LCD controller of the processor operates in 18-bit or 16-bit RGB mode and it can drive TFT displays with resolutions up to 1024 x 768 (XGA). The pixel clock for the display data can be generated by the internal PLLSAI_R.

The following table describes the function of the data and control lines from the STM32Fxx9 LTDC controller.

Signal	Description
LTDC_R[7:2]	6 color data RED
LTDC_G[7:2]	6 color data GREEN
LTDC_B[7:2]	6 color data BLUE
LTDC_VSYNC	Vertical synchronization signal
LTDC_HSYNC	horizontal synchronization signal
LTDC_DE	Data enable signal, if active color data are valid
LTDC_CLK	Display clock

4.4.1 Color mapping in 16/18bit mode

The following table shows the RGB colour mapping on the TCDC_X[xx] pins available at the castellated mounting holes on the edge of the CPU module.

LTDC_X[xx]	Module pin	CPU pin	RGB565 (16bit)	RGB666 (18bit)
LTDC_R2	29	PJ1	-	R0
LTDC_R3	30	PJ2	R0	R1
LTDC_R4	31	PJ3	R1	R2
LTDC_R5	32	PJ4	R2	R3
LTDC_R6	33	PJ5	R3	R4
LTDC_R7	34	PG6	R4	R5
LTDC_G2	78	PI15	G0	G0
LTDC_G3	79	PG10	G1	G1
LTDC_G4	80	PJ13	G2	G2
LTDC_G5	81	PH4	G3	G3
LTDC_G6	82	PI11	G4	G4
LTDC_G7	83	PB5	G5	G5
LTDC_B2	85	PJ14	-	B0
LTDC_B3	86	PJ15	B0	B1
LTDC_B4	87	PK3	B1	B2
LTDC_B5	88	PI5	B2	B3
LTDC_B6	89	PK6	B3	B4
LTDC_B7	90	PK7	B4	B5
LTDC_VSYNC	11	PI13		
LTDC_HSYNC	10	PI12		
LTDC_DE	9	PK7		
LTDC_CLK	12	PI14		

4.5 Ethernet

The emSTAMP-Neon-CMx module provides an Ethernet interface with up to 100BASE-TX full duplex. The Ethernet RMII interface of the STM32Fxx9 CPU is connected to the external PHY LAN8720A from Microchip. The PHY address is set to 0.

A 25MHz clock is generated by the STM32Fxx9 on its microcontroller clock output (MCO1 available at pin PA8) and connected to the XTAL1/CLKIN of the PHY. The PHY operates in the REF_CLOCK_OUT mode, i.e. the reference clock is sourced at the nINT/REFCLOCK pin of the PHY.

The reset input nRST of the PHY is controlled via the PC0 of the STM32Fxx9. An external 10k pull-down resistor is connected to this signal to hold the PHY in reset during start-up of the CPU.

The PHY LAN8720A is integrated on the CPU module so that an Ethernet Jack (with integrated magnetics) may be directly connected to the modules Ethernet pins ETH_RDP/ETH_RDM and ETH_TDP/ETH_TDM which are available at the castellated mounting holes of the module. An appropriate 1:1 transformer with a 100nF capacitor to GND and a 3.3V supply at each center tap pin must be added externally. Link or traffic indication signals for additional LEDs are not provided.

Signal	Module pin	CPU pin
ETH_RDP	28	-
ETH_RDM	27	-
ETH_TDP	25	-
ETH_TDM	24	-
MCO1	-	PA8
PHY_nRST	-	PC0

4.6 USB 2.0 Host

The USB 2.0 Host interface is connected to the USB_OTG_HS interface of the STM32Fxx9 and operates in full-speed mode. The pin PH10 of the STM32Fxx9 processor is used as active low USB Host Power Enable output (USB_OTG_HS_VBUS_EN#). The pin PH8 of the CPU is the corresponding overcurrent input (USB_OTG_HS_OC#) of the USB Host interface.

Signal	Module pin	CPU pin
USB_OTG_HS_OC#	41	PH8
USB_OTG_HS_VBUS_EN#	42	PH10
USB_OTG_HS_DM	43	PB14
USB_OTG_HS_DP	44	PB15

4.7 USB 2.0 Device

The USB 2.0 Device interface is connected to the USB_OTG_FS interface of the STM32Fxx9 and operates in full-speed mode. The signal USB_OTG_FS_VBUS at module pin 65 is for the VBUS detection of the Up-stream port.

Note: maximum input voltage for USB_OTG_FS_VBUS is 4.0V if the emSTAMP-Neon is not powered and connected to an active USB-Host. STMicroelectronics proposes a resistor divider to limit the maximum voltage of this pin. For Details please refer to chapter 3.1.1 of application note AN4879 [5] from STMicroelectronics.

Signal	Module pin	CPU pin
USB_OTG_FS_VBUS	65	PA9
USB_OTG_FS_DM	67	PA11
USB_OTG_FS_DP	68	PA12

4.8 CAN Interface

The STM32Fxx9 provides the Basic Extended CAN peripheral (bxCAN) to interface the CAN network. The bxCAN is compliant to the CAN protocol specification 2.0 Part A and B. The LVTTTL transmit and receive signals of the CAN channel are directly connected to the castellated mounting holes of the module and supports Bit rates of up to 1 Mbit/s.

Signal	Module pin	CPU pin
CAN1_TX	7	PB9
CAN1_RX	8	PI9

4.9 SDIO Interface

The STM32Fxx9 includes an SDIO interface to connect MultiMediaCards, SD memory cards and SDIO cards. The SDIO interface allows data transfer of up to 50MHz and supports SD V2.0, SDIO V2.0 and MMC V4.2. The SDIO interface is connected with four data lines to the castellated mounting holes of the module.

Signal	Module pin	CPU pin
SDIO_CMD	58	PD2
SDIO_CD#	59	PA10
SDIO_D0	60	PC8
SDIO_D1	61	PC9
SDIO_D2	62	PC10
SDIO_D3	63	PC11
SDIO_CK	64	PC12

The active low signal for card-detect (SDIO_CD#) is connected to 10k pull-up resistor on the CPU module.

4.10 Serial Ports

The STM32Fxx9 provides up to 8 serial ports. The ports USART2 and USART3 are directly connected as LVTTTL signals to the castellated mounting holes of the module. Both ports support a maximum baud rate of 2.81 Mbit/s (with oversampling rate 16). USART2 additionally provides hardware control lines RTS and CTS.

The following table shows the usage of the available USARTs:

Signal	Module pin	CPU pin
USART2_RX	74	PD6
USART2_TX	75	PD5
USART2_CTS	76	PD3
USART2_RTS	77	PD4
USART3_RX	39	PB11
USART3_TX	40	PB10

4.11 I²C Interface

Up to three I2C bus interface are available at the STM32Fxx9. The interface I2C1 is directly connected as LVTTTL signals to the castellated mounting holes of the module. The I2C1 is equipped with 2k2 pull-up resistors and supports standard (up to 100KHz) and fast mode (up to 400KHz). I2C1 also support SMBus 2.0/PMBus.

Signal	Module pin	CPU pin
I2C1_SDA	92	PB7
I2C1_SCL	91	PB8

4.12 SPI Interfaces

The STM32Fxx9 provides up to 6 SPIs. On the emSTAMP-Neon module two interfaces SPI2 and SPI5 are connected to the castellated mounting holes. SPI5 can communicate at up to 45Mbit/s and SPI2 up to 22.5Mbit/s.

SPI5 does **not** have a hardware chip select (SPI5_NSS) pin connected to the mounting holes of the module. Use a GPIO to generate the chip select signal by software control.

The following table shows the usage of the available SPIs:

Signal	Module pin	CPU pin
SPI2_MOSI	47	PI3
SPI2_MISO	48	PC2
SPI2_SCK	49	PI1
SPI2_NSS	50	PI0
SPI5_MOSI	36	PF9
SPI5_MISO	38	PH7
SPI5_SCK	37	PH6

4.13 Audio Interface

The STM32Fxx9 offers a Serial Audio Interface (SAI) with two independent sub-blocks. The SAI supports audio protocols like I2S, PCM/DSP, TDM and SPDIF.

On the emSTAMP-Neon-CMx module the sub-block SAI-A of the STM32Fxx9 is connected to the mounting holes. A master clock output signal is also connected.

The clock for the Serial Audio Interface is derived from the main PLL (PLLM) and therefore it has a small deviation to the desired audio frequency. The audio PLL (PLLI2S) can be used to minimize the frequency error. For example a sample rate of 44.1 KHz will have an error of 0,04 %.

Signal	Module pin	CPU pin
SAI1_FS_A	3	PE4
SAI1_SCK_A	4	PE5
SAI1_SD_A	5	PE6
SAI1_MCLK_A	6	PE2

4.14 GPIOs / PWM

The emSTAMP-Neon-CMx module offers six GPIO on its mounting holes.

As a feature the six channels of the Advanced-Control timer TIM8 are available as alternative port functions for these pins. The timer TIM8 can be used to generate three-phase PWM motor control signal with complementary outputs and programmable dead times.

Signal	Module pin	CPU pin
GPIO1/TIM8_CH1N	51	PH13
GPIO2/TIM8_CH1	52	PC6
GPIO3/TIM8_CH2N	53	PH14
GPIO4/TIM8_CH2	54	PC7
GPIO5/TIM8_CH3N	55	PH15
GPIO6/TIM8_CH3	56	PI7

4.15 Analog to Digital Converter (ADC)

The STM32Fxx9 provides three independent analog to digital converter with 12 bit resolution. On the castellated mounting holes of the emSTAMP-Neon-CMx module, 3 pins are connected to the 3 ADCs of the CPU. The reference voltage for the three analog to digital converter (VREF+) is set to 3.3V.

Signal	Module pin	CPU pin
ADC1_IN9	23	PB1
ADC2_IN6	21	PA6
ADC3_IN3	22	PA3

4.16 Digital to Analog Converter (DAC)

The STM32Fxx9 provides two independent digital to analog converter channels with 12 bit resolution to generate two analog voltage outputs. The input voltage V_{REF+} of the DAC is set to 3.3V

Signal	Module pin	CPU pin
DAC_OUT1	19	PA4
DAC_OUT2	20	PA5

4.17 WKUP Signal

The WKUP Signal may be used to wake the CPU from standby mode (if enabled). If enabled, the WKUP-pin is connected to an internal pull-down resistor. The CPU wakes up from standby mode by a rising edge on the WKUP-Pin. The WKUP-Pin should be driven by open drain/collector outputs, or connected to GND through a switch. If unused, leave this pin open.

Signal	Module pin	CPU pin
SYS_WKUP	18	PA0

4.18 Reset

The STM32Fxx9 has an internal power supply supervisor, which includes an integrated power-on-reset (POR) and a power-down reset (PDR). On the emSTAMP-Neon module the POR and PDR circuitry is always enabled by setting the PDR_ON pin of the CPU to high.

The module provides a STM32_RES# pin to which an active low external reset signal may be applied to generate a reset of the CPU. This pin is directly connected to the RES# pin of the STM32Fxx9 and has an external pull-up resistor and a 100nF capacitor. The STM32_RES# pin should be driven by open drain/collector outputs, or connected to GND through a switch. If unused, leave this pin open.

Signal	Module pin	CPU pin
STM32_RES#	17	RST#

4.19 JTAG Debug

For programming and debugging the STM32Fxx9 offers two interfaces:

- Serial Wire Debug (SWD)
- JTAG Debug

Both interfaces are available via the same pins on the castellated mounting holes of the module.

Signal	Module pin	CPU pin
JTAG_TMS/SWDIO	69	PA13
JTAG_TCLK/SWCLK	70	PA14
JTAG_TDI	71	PA15
JTAG_TDO	72	PB3
JTAG_TRST#	73	PB4

4.20 Power Supply

Supply	Direction	V_{min}	V_{typ}	V_{max}
+3V3	to module	3.10V	3.3V	3.50V
V_{BAT}	to module	1.65V		3.60V

4.20.1 +3V3 Supply

The emSTAMP-Neon module will be powered by a single +3V3 supply. No additional supplies are required to use the basic functionality of the module.

4.20.2 Battery backup voltage V_{BAT}

By connecting the V_{BAT} supply pin of the STM32Fx68 to a battery or another voltage source, the internal RTC and/or the backup SRAM can be supplied when the 3.3V supply is turned off. For details of current consumption in battery backup mode, please refer to the datasheets [2] and [4].

5 Castellation Connector

For the placement and the orientation of the 92 castellated mounting holes of the emSTAMP-Neon module, please refer to chapter “Dimensional Drawing”.

Abbreviations:

RFU reserved for further use

AI analogue input

AO analogue output

I digital input

O digital output

I/O digital bidirectional

O(OD) digital open drain output

PU xK x K Ω pullup resistor

PD xK x K Ω pulldown resistor

SR xR x Ω series resistor

IPU xK processor internal x K Ω pullup resistor

IPD xK transistor internal x K Ω pulldown resistor

In the following table the castellated mounting holes are referred to as “Module Pins”.

Module Pin	Signal	CPU Pin	Direction	Termination
1	VDD	VDD	-	
2	VSS	VSS	-	
3	SAI1_FS_A	PE4	I/O	
4	SAI1_SCK_A	PE5	I/O	
5	SAI1_SD_A	PE6	I/O	
6	SAI1_MCLK_A	PE2	O	
7	CAN1_TX	PB9	O	
8	CAN1_RX	PI9	I	PU 10K
9	LTDC_DE	PK7	O	
10	LTDC_HSYNC	PI12	O	
11	LTDC_VSYNC	PI13	O	
12	LTDC_CLK	PI14	O	
13	VSS	VSS	-	
14	BOOT_0	BOOT0	I	PD 1K
15	BOOT_1	PB2/BOOT1	I	PD 1K
16	VBAT	VBAT	-	
17	STM32_RES#	NRST	I	PU 10K
18	SYS_WKUP	PA0/WKUP	I	
19	DAC_OUT1	PA4	AO	
20	DAC_OUT2	PA5	AO	
21	ADC2_IN6	PA6	AI	
22	ADC3_IN3	PA3	AI	
23	ADC1_IN9	PB1	AI	
24	ETH_TDM	PA7	-	
25	ETH_TDP	PC1	-	
26	VSS	VSS	-	
27	ETH_RDM	PA2	-	
28	ETH_RDP	PA1	-	
29	LTDC_R2	PJ1	O	
30	LTDC_R3	PJ2	O	
31	LTDC_R4	PJ3	O	
32	LTDC_R5	PJ4	O	
33	LTDC_R6	PJ5	O	

34	LTDC_R7	PG6	O	
35	VSS	VSS	-	
36	SPI5_MOSI	PF9	O	
37	SPI5_SCK	PH6	O	
38	SPI5_MISO	PH7	I	
39	USART3_RX	PB11	I	
40	USART3_TX	PB10	O	
41	USB_OTG_HS_OC#	PH8	I	
42	USB_OTG_HS_VBUS_EN	PH10	O	
43	USB_OTG_HS_DM	PB14	I/O	
44	USB_OTG_HS_DP	PB15	I/O	
45	VSS	VSS	-	
46	VDD	VDD	-	
47	SPI2_MOSI	PI3	O	
48	SPI2_MISO	PC2	I	
49	SPI2_SCK	PI1	O	
50	SPI2_NSS	PI0	O	
51	GPIO1/TIM8_CH1N	PH13	I/O	
52	GPIO2/TIM8_CH1	PC6	I/O	
53	GPIO3/TIM8_CH2N	PH14	I/O	
54	GPIO4/TIM8_CH2	PC7	I/O	
55	GPIO5/TIM8_CH3N	PH15	I/O	
56	GPIO6/TIM8_CH3	PI7	I/O	
57	VSS	VSS	-	
58	SDIO_CMD	PD2	O	PU 10K
59	SDIO_CD#	PA10	I/O	PU 10K
60	SDIO_D0	PC8	I/O	PU 47K
61	SDIO_D1	PC9	I/O	PU 47K
62	SDIO_D2	PC10	I/O	PU 47K
63	SDIO_D3	PC11	I/O	PU 47K
64	SDIO_CK	PC12	O	SR 33R
65	USB_OTG_FS_VBUS	PA9	AI	
66	VSS	VSS	-	
67	USB_OTG_FS_DM	PA11	I/O	
68	USB_OTG_FS_DP	PA12	I/O	
69	SYS_JTMS-SWDIO	PA13	I/O	PU 10K
70	SYS_JTCK-SWCLK	PA14	O	PD 10K
71	SYS_JTDI	PA15	I	PU 10K
72	SYS_JTDO-SWO	PB3	O	
73	SYS_JTRST	PB4	O	PU 10K
74	USART2_RX	PD6	I	
75	USART2_TX	PD5	O	
76	USART2_CTS	PD3	I	
77	USART2_RTS	PD4	O	
78	LTDC_G2	PI15	O	
79	LTDC_G3	PG10	O	
80	LTDC_G4	PJ13	O	
81	LTDC_G5	PH4	O	
82	LTDC_G6	PI11	O	
83	LTDC_G7	PB5	O	
84	VSS	VSS	-	
85	LTDC_B2	PJ14	O	
86	LTDC_B3	PJ15	O	
87	LTDC_B4	PK3	O	
88	LTDC_B5	PI5	O	
89	LTDC_B6	PK5	O	
90	LTDC_B7	PK6	O	
91	I2C1_SCL	PB8	O(OD)	PU 2K2
92	I2C1_SDA	PB7	I/O(OD)	PU 2K2

6 Technical Characteristics

6.1 Electrical Specifications

Supply voltage	3.3V, +/-5%
Current consumption	up to 360mA (emSTAMP-Neon-CM4) up to 480mA (emSTAMP-Neon-CM7)

6.2 Environmental Specifications

Operating temperature	
Standard:	0 ... +70°C
Storage temperature	-10 ... +85°C
Relative humidity	0 ... 95 %, non-condensing

6.3 Mechanical Specifications

Weight	3 g
Board	FR-4
Dimensions	28.0 mm x 28.0 mm x 2.5 mm

7 Dimensional Drawing

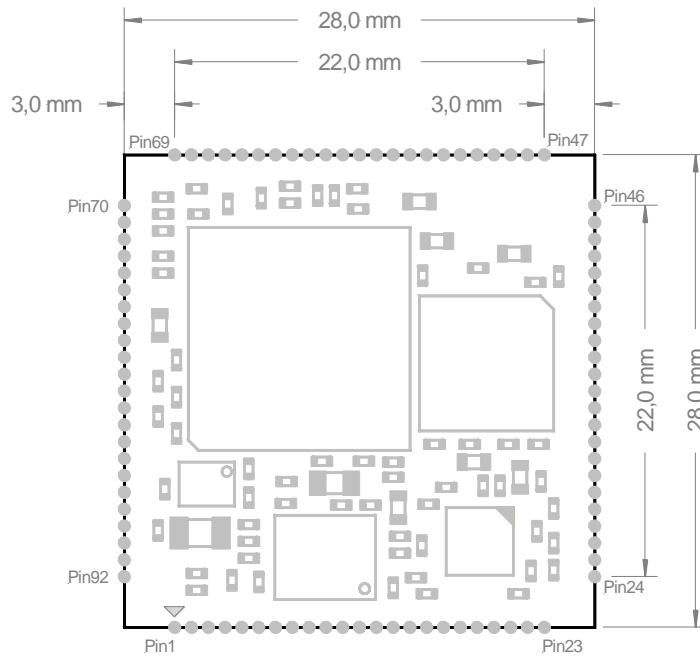

Top View on the assembly side.

8 Recommended patterns for soldering

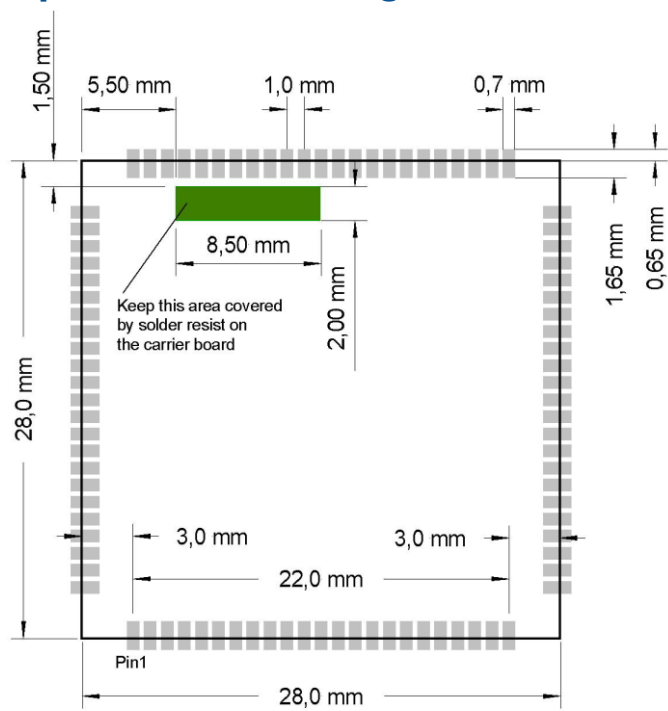

Top View on the assembly side.

9 References

- [1] RM0386
Reference manual
STM32F469xx and STM32F479xx
advanced ARM®-based 32-bit MCUs
DocID026744 Rev 3, January 2017
STMicroelectronics

- [2] STM32F469xx
Datasheet
DocID028196 Rev 4, March 2017
STMicroelectronics

- [3] RM0410
Reference manual
STM32F76xxx and STM32F77xxx
advanced ARM®-based 32-bit MCUs
Rev 4, March 2018
STMicroelectronics

- [4] STM32F76xxx
Datasheet
DocID029041, Rev 6, September 2017
STMicroelectronics

- [5] AN4879
Application Note USB hardware and PCB guidelines
Rev 4, December 2018
STMicroelectronics

- [6] STM32F479xx
Datasheet
DS11118 Rev 5, May 2018
STMicroelectronics